

## HDC-6605P(N)-28/36/60/V

[www.asia.security.honeywell.com](http://www.asia.security.honeywell.com)

### 600TVL HIGH RESOLUTION DAY/NIGHT FIXED DOME

Honeywell HDC-6605P(N) dome camera series delivers high resolution images with 600TVL to offer accurate color reproduction performance. 2.5mm / 3.6mm / 6.0mm fixed lens and 2.8 – 10mm vari-focal lens are available to offer the best solution for different surveillance requirements.

Featuring Digital Noise Reduction (DNR) and software-enhanced day/night (SDN) functions, the HDC-6605P(N) guarantees high quality image delivery in various environments. Equipped with Wide Dynamic Range (WDR), this dome camera series is ideal for 24x7 surveillance in facilities where intensity of illumination can vary excessively.

Honeywell's proprietary BMB™ technology (Black Mask BLC) is another key function of the HDC-6605P(N) series. BMB™ detects, masks and blocks glares automatically, making the image quality of the surroundings unaffected and remains visible and clear. It is particularly useful and suitable for parking lot and highway surveillance at night time.

#### Market Opportunities

Honeywell HDC-6605P(N) dome camera series is a high quality security and surveillance solution. With 600TVL, WDR, BMB™, DNR, and fixed/vari-focal lens available, this camera series is ideal for shopping centres, hotels, office buildings, financial institutions, entrances, parking lots, highways and so forth.

#### FEATURES

- Ultra high resolution: 600 TVL
- Honeywell BMB™ technology
- AES, BLC, White Balance, Digital WDR, digital spot compensation
- Lens shaded control, horizontal mirror, anti-flickering
- Motion detection, privacy masking
- Distance reference lines onto the display for car reverse
- OSD menu
- Adjustable triangular bracket
- 24V AC / 12V DC



## HDC-6605P(N)-28/36/60/V

www.asia.security.honeywell.com

### 600TVL HIGH RESOLUTION DAY/NIGHT FIXED DOME

#### SPECIFICATIONS

Model	HDC-6605P(N)-28	HDC-6605P(N)-36	HDC-6605P(N)-60	HDC-6605P(N)V
Scanning System	2:1 interlaced scan			
Image Sensor	1/3" SONY Super HAD II CCD			
Effective Pixels	HDC-6605P-28: 752 x 582 HDC-6605N-28: 768 x 494	HDC-6605P-36: 752 x 582 HDC-6605N-36: 768 x 494	HDC-6605P-60: 752 x 582 HDC-6605N-60: 768 x 494	HDC-6605PV: 752 x 582 HDC-6605NV: 768 x 494
Horizontal Resolution	600TVL (color)			
Lens	2.8mm	3.6mm	6mm	2.8 - 10mm vari-focal
Minimum Illumination	≤ 0.1Lux / F1.2 (color); 0.01Lux / F1.2 (B/W)			
Video Output	1.0Vp-p composite video, 75Ohm			
Sync. System	Internal			
S/N Ratio	≥ 50dB (AGC Off)			
Gain Control	High / Mid / Low / Off			
Electronic Shutter	Auto / Anti-flickering (FLK) / Manual (1/50 - 1/100000)			
Day/Night	Auto / B/W / Color / EXT			
White Balance	ATW 1 / ATW 2 / AWC: SET/Manual			
BLC	BMB™ / BLC / Off			
Digital WDR	Off / On (0-63 levels adjustable)			
Gamma	LCD: 0.55 / CRT: 0.45 / User-defined (0.01 - 1.0 adjustable)			
DNR	2DNR On / Off			
Mirror	Off / H. Mirror			
Privacy Masking	Off / On (8 zones selectable)			
Motion Detection	Off / On (4 zones adjustable)			
Picture Adjustment	Contrast / Sharpness			
Display Mode	CRT / LCD / User			
OSD	English / Simplified Chinese			
Mounting	Surface mount			
Power Supply	130 - 180mA / 12V DC; 60 - 100mA / 24V AC (± 10%)			
Power Consumption	<2.5W			
Dimensions	133(D) x 96.65(H) mm			
Weight	301g			
Operating Temperature	-20°C to 50°C			
Relative Humidity	80% (non-condensing)			
Certificate	CE, FCC			

**\*Note:** Honeywell reserves the right, without notification, to make changes in product design and/or specifications.

## HDC-6605P(N)-28/36/60/V

www.asia.security.honeywell.com

### 600TVL HIGH RESOLUTION DAY/NIGHT FIXED DOME

#### DIMENSIONS

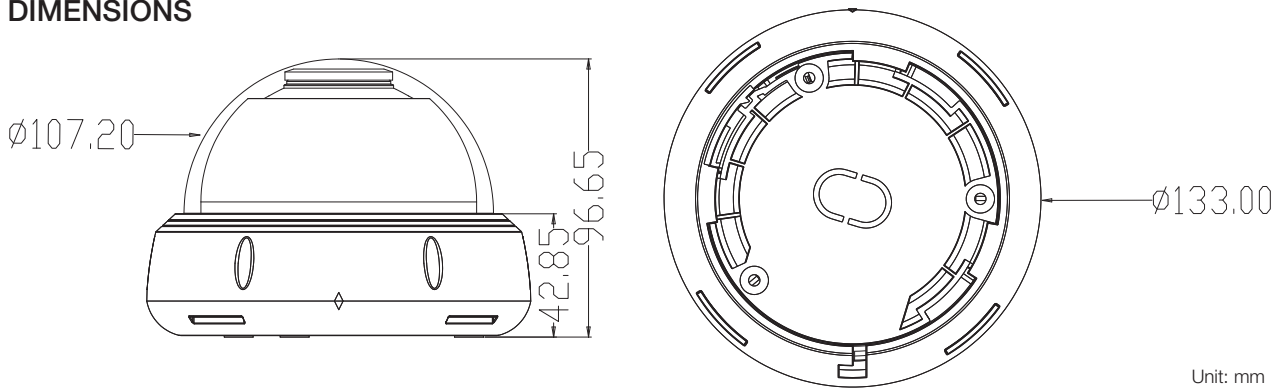

Unit: mm

#### ORDERING

HDC-6605P-28	600TVL fixed dome camera, 1/3"CCD, 2.8mm, SDN, 12V DC / 24V AC, PAL
HDC-6605N-28	600TVL fixed dome camera, 1/3"CCD, 2.8mm, SDN, 12V DC / 24V AC, NTSC
HDC-6605P-36	600TVL fixed dome camera, 1/3"CCD, 3.6mm, SDN, 12V DC / 24V AC, PAL
HDC-6605N-36	600TVL fixed dome camera, 1/3"CCD, 3.6mm, SDN, 12V DC / 24V AC, NTSC
HDC-6605P-60	600TVL fixed dome camera, 1/3"CCD, 6mm, SDN, 12V DC / 24V AC, PAL
HDC-6605N-60	600TVL fixed dome camera, 1/3"CCD, 6mm, SDN, 12V DC / 24V AC, NTSC
HDC-6605PV	600TVL fixed dome camera, 1/3"CCD, 2.8 - 10mm, SDN, 12V DC / 24V AC, PAL
HDC-6605NV	600TVL fixed dome camera, 1/3"CCD, 2.8 - 10mm, SDN, 12V DC / 24V AC, NTSC

# HDC-6605P(N)-28/36/60/V

[www.asia.security.honeywell.com](http://www.asia.security.honeywell.com)

---

## 600TVL HIGH RESOLUTION DAY/NIGHT FIXED DOME

For more information:

Security Asia Pacific Headquarters  
Security Australia  
Security Australia National Sales Hotline  
Security China  
Security China Customer Service Hotline

Tel: (86) 21-2219 6888  
Tel: (61) 2-9353 7000  
Tel: 1300 765 532  
Tel: (86) 21-2219 6888  
Tel: 400-8800-330

Security Hong Kong  
Security India  
Security Korea  
Security Singapore  
Security Taiwan

Tel: (852) 2405 2323  
Tel: (91) 124 4975000  
Tel: (82) 2-799 6130  
Tel: (65) 6333 9563  
Tel: (886) 2-2245 1000

[www.asia.security.honeywell.com](http://www.asia.security.honeywell.com)  
[security.ap@honeywell.com](mailto:security.ap@honeywell.com)

**Honeywell Security Group**  
Automation & Control Solutions  
Honeywell International Inc.  
[www.security.honeywell.com](http://www.security.honeywell.com)

Jun 2012  
© 2012 Honeywell International Inc.

The Honeywell logo is displayed in a bold, red, sans-serif font.